

# Mineral waste recycling for added value

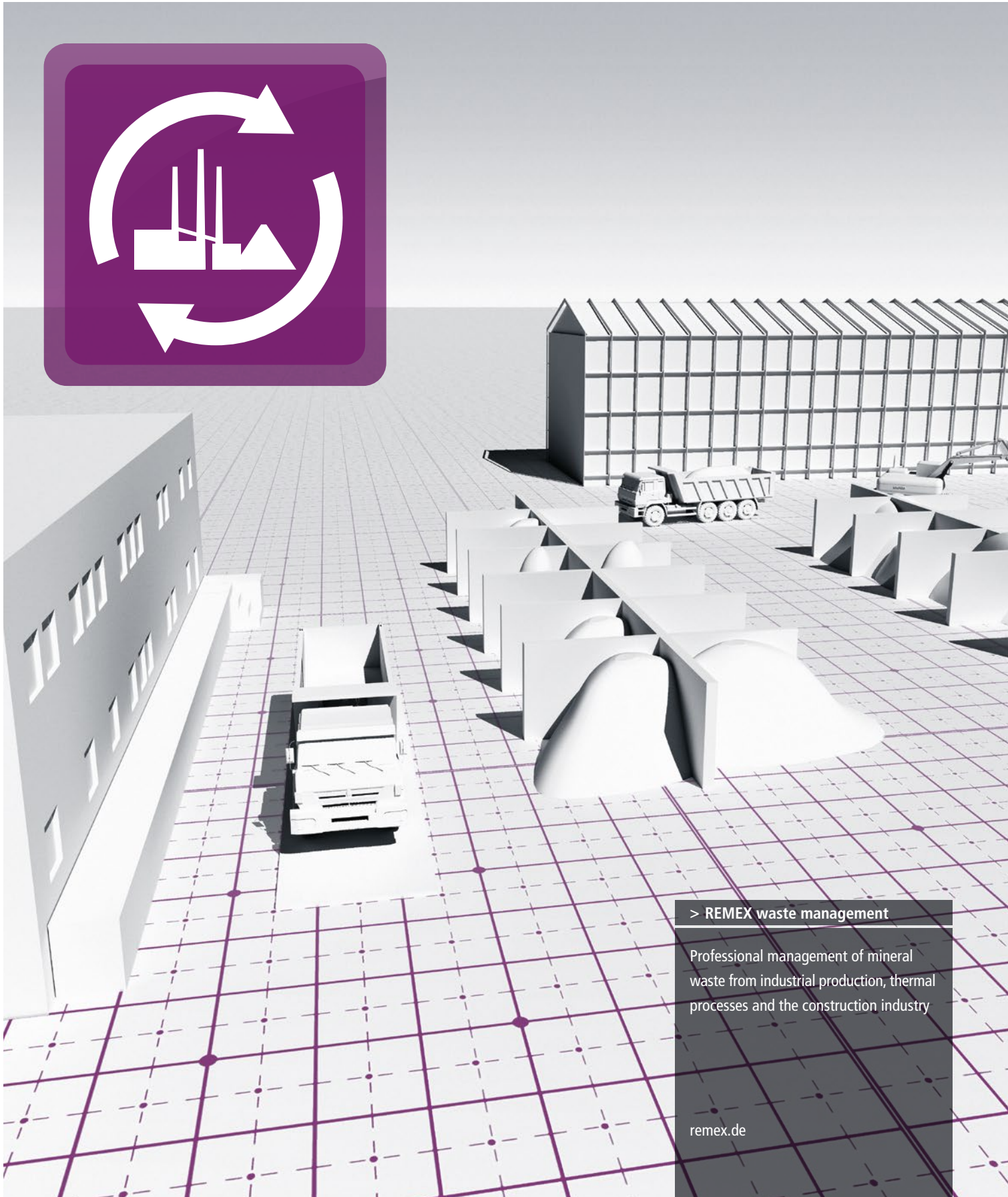

## > REMEX waste management

Professional management of mineral waste from industrial production, thermal processes and the construction industry

## Ecological added value for waste

Today's mineral waste is an important resource for tomorrow – provided it receives the right professional treatment. REMEX's core activities involve processing mineral materials from the construction, energy and industry sectors, and returning these to the material cycle. Over the years, we have developed from this core competence into an important partner for public authorities and companies: As part of our services, we offer a full range of services from logistics and processing to recovery or safe disposal.



For over **40** years  
REMEX stands for recovering the resource potential of waste

### Specialist for mineral management

Whether in incineration processes, the thermal treatment of waste in Waste-to-Energy plants, industrial production, the demolition of buildings or road remediation measures: Mineral waste is produced in many different ways. These substances are for example ash, slag or filter dust, but also soil, road rubble or construction and demolition waste. Our acceptance spectrum ranges from slightly contaminated to hazardous waste.

### Always bringing out the best

As a certified waste management company, we know what we are talking about and – even more importantly – we act accordingly. Our premise is: Everything that is recyclable will be recycled. In order to achieve an optimal recycling rate, we continuously invest in new technologies and optimally trained personnel. For mineral waste that cannot be made usable again due to its pollutant load, we also offer reliable disposal in landfills above or below ground.



# Responsible waste management

As a recycling company, we organise the complete mineral material cycle, and take into account all recycling and recovery possibilities for each material.



## Industrial waste

Industrial mineral waste is a by-product of numerous production processes. With reliable mineral waste management, we unburden our industrial clients from waste such as slag, ash, sludge and sand.

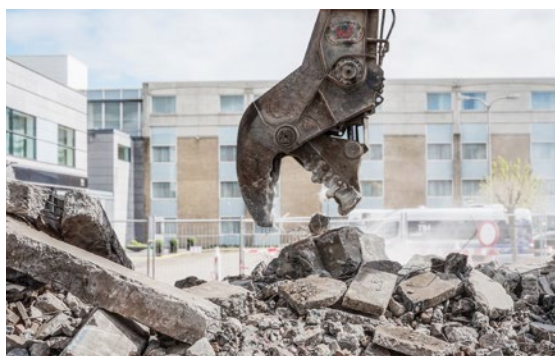

## Soil, construction and demolition waste

REMEX creates space on construction sites: We carry out all steps involved in the management of mineral construction waste. We process road rubble and construction and demolition waste, so that it can be reused as recycled aggregate.



## Ash and slag from waste incineration

The incineration of municipal solid waste in Waste-to-Energy plants leaves behind incinerator bottom ash, which is ideal for use as secondary aggregate in various applications for earthworks, road construction or landfill construction.

[waste-management.remex.de](http://waste-management.remex.de)

For each waste stream, we provide further information online in the form of individual webpages.

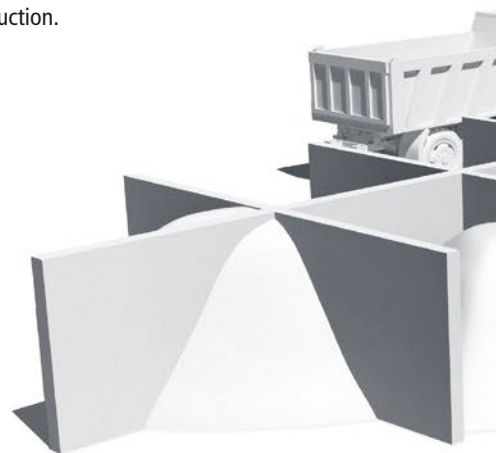

### Track ballast

Efficient solutions for the management of worn track ballast are required for the remediation of railway lines. REMEX offers appropriate treatment options and thus enables the ballast to be reused, for example, as recycled ballast in track construction.



### Filter dust and fly ash

In waste incineration plants and in air pollution control processes, hazardous waste in the form of fly ash, filter dusts and flue gas cleaning residues (APCr) accumulate. These and other hazardous waste streams require management by specialists.



### Street sweepings

The REMEX Group also processes street sweepings in its own facilities as part of its waste management services. The treated fine fraction is used in earthworks or landfill construction and the medium fraction is usually composted. Any remaining parts are thermally treated.

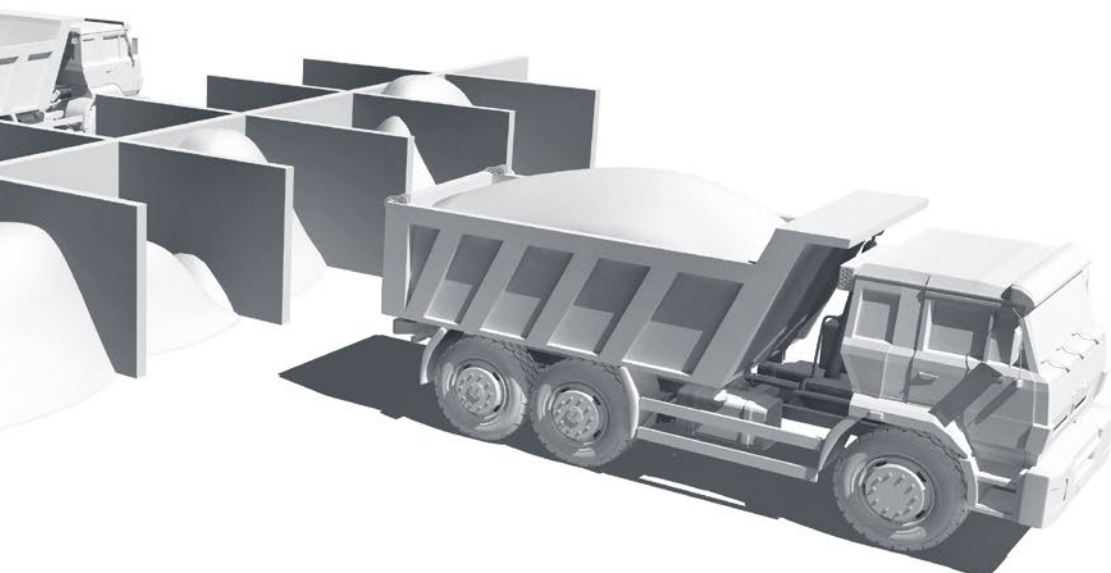

Professional collection and processing of the various material flows is decisive for high recycling rates

## Our services at a glance

We offer all necessary management services for mineral waste: From pollutant evaluation and the classification of waste, logistics, temporary storage, processing and the utilisation of raw materials contained in mineral waste, to disposal if recycling is not possible.



Complete waste management for mineral waste of all pollution levels



Notification of waste for international transport



Determination of the pollutant load in cooperation with recognised test laboratories



Access to recovery options e.g. in earthworks, road construction, landfills and underground stowage

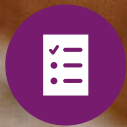

Assistance in the evaluation and classification of the waste type



Provision of logistics services via truck, ship and rail

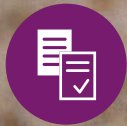

Support in obtaining permits, verifications and documentation

# REMEX®

WORKING FOR THE FUTURE

Being a specialist for managing and recycling mineral waste as well as for remediation work, underground stowage and landfill operation, REMEX is part of the REMONDIS Group, one of the world's largest recycling, service and water companies. The company group has branches and associated businesses in more than 30 countries across Europe, Africa, Asia and Australia. With over 30,000 employees, the group serves around 30 million people as well as many thousands of companies. The highest levels of quality. Working for the future.

REMEX GmbH  
Am Fallhammer 1 // 40221 Düsseldorf  
Germany // T +49 211 17160-0  
F +49 211 17160-420 // [info@remex.de](mailto:info@remex.de)  
[remex.de](http://remex.de)